

Busbar system for distribution boards 250 mm 8HP1790

Allgemeine Informationen

Products_Model	ET0779302
EAN	4011209587557
Producer	Siemens Indus.Sector
Producer-Model	8HP1790
Producer-Typ	8HP1790
min. Order	
Class	Sammelschienensystem für Verteiler

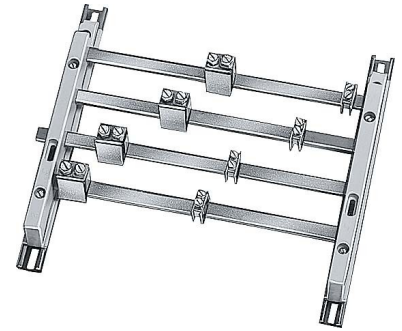

Technische Informationen

Breite	250mm
Polzahl	
Schienenhöhe	12mm
Schienenstärke	5mm
Bemessungsstrom	250A

[Busbar system for distribution boards 250 mm 8HP1790 online kaufen](#)

